

# KAPPA 15 A

max. 16 l/min - 5 GPM · 20 bar - 290 PSI · 1450 RPM

**A** KAPPA 15 A cod. 801600

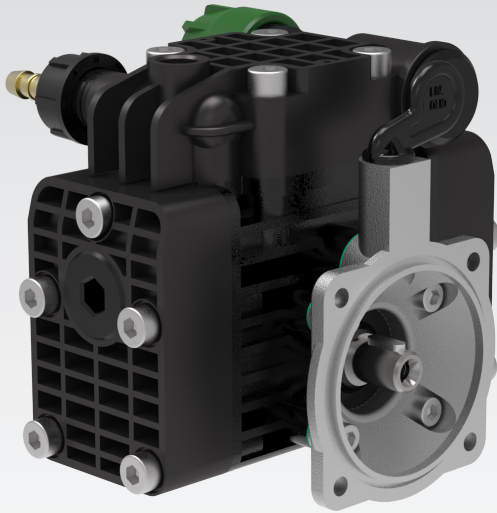

Membrane **GREENTECH** di serie  
**GREENTECH** diaphragm as standard  
cod. 090305

RPM	0 bar / 0 PSI				5 bar / 72 PSI				10 bar / 145 PSI				15 bar / 217 PSI				20 bar / 290 PSI				Peso Weight	
	Portata Flow rate		Potenza Power		Portata Flow rate		Potenza Power		Portata Flow rate		Potenza Power		Portata Flow rate		Potenza Power		Portata Flow rate		Potenza Power			
	l/min	GPM	HP	kW	l/min	GPM	HP	kW	l/min	GPM	HP	kW	l/min	GPM	HP	kW	l/min	GPM	HP	kW		
<b>1300</b>	14,0	3,7	0,1	0,1	11,2	3,0	0,2	0,2	10,5	2,8	0,3	0,2	10,2	2,7	0,4	0,3	10,0	2,6	0,5	0,4	2,5	5,5
<b>1350</b>	14,5	3,8	0,1	0,1	11,5	3,0	0,2	0,2	10,7	2,8	0,3	0,2	10,4	2,7	0,4	0,3	10,2	2,7	0,5	0,4		
<b>1400</b>	15,0	4,0	0,2	0,1	11,8	3,1	0,2	0,2	10,9	2,9	0,3	0,2	10,6	2,8	0,4	0,3	10,4	2,7	0,5	0,4		
<b>1450</b>	16,0	5,0	0,2	0,1	12,1	3,2	0,2	0,2	11,1	2,9	0,3	0,2	10,8	2,9	0,4	0,3	10,6	2,8	0,6	0,4		

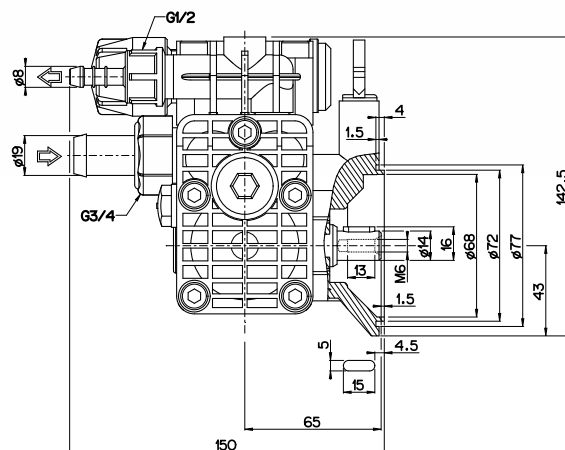
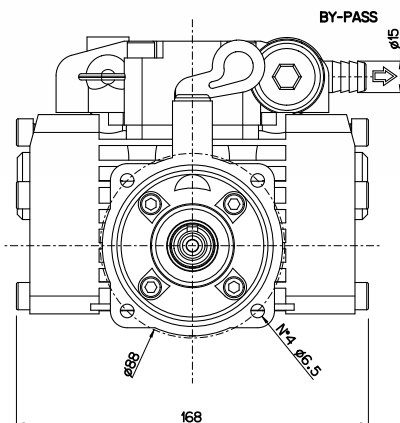

# KAPPA 15 A

## Versioni Versions

**A** cod. 801600



## Applicazioni Shaft adaptors

Riduttore per motore a scoppio  
Gear reduction for gasoline/diesel engine



S 124

vedi pag 89 see page 89



S 135